

INDUSTRIAL VACUUM CLEANER

WET & DRY VACUUM CLEANER
OPERATION INSTRUCTION

JS154

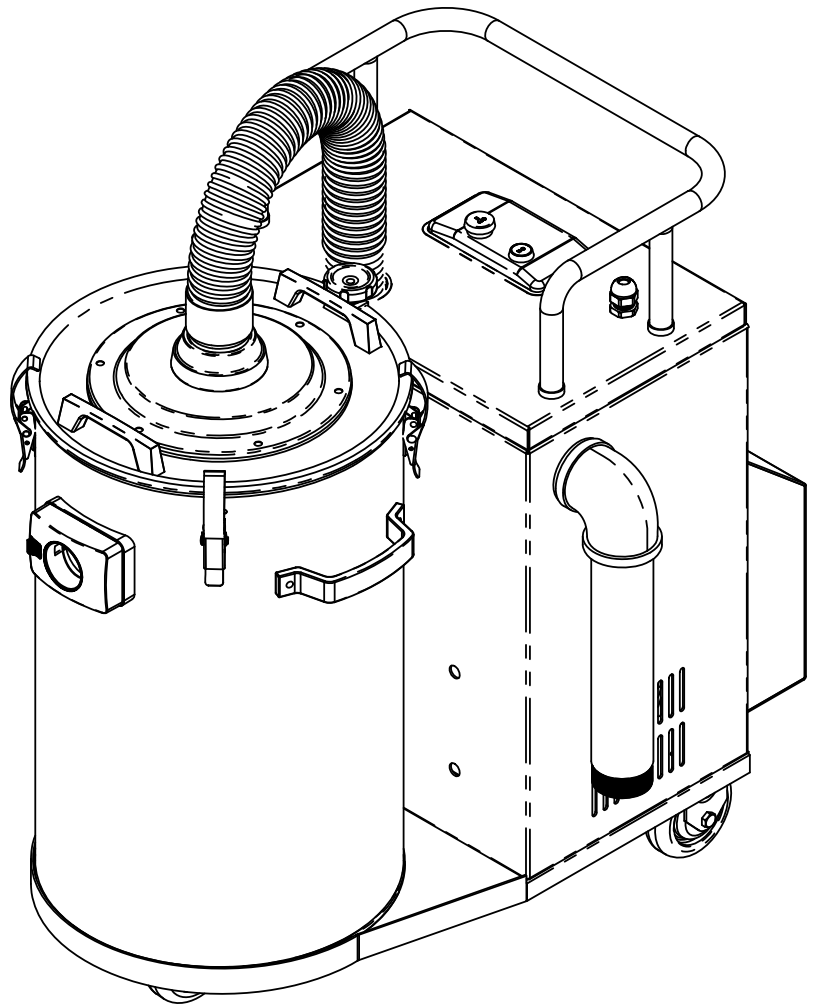

Thank you for purchasing our products.

©For completely understanding the functions of this product and operating it correctly please read this Operation Instruction carefully before using. Please keep this instruction for future reference.

OPERATION INSTRUCTION

1 Safety Rules

For using safely, please read and understand "Safety Rules" carefully before using.

Please follow this "Safety Rules of the Operation Instruction" to ensure a safe and accident-free operation.

※After reading this instruction, please keep it in an obviously place for reference.



Caution It will cause death or serious injury.



Notice

- This appliance is not intended for users with insufficient sensory or mental capabilities, or lack of experience and knowledge, unless they are given supervision or instruction concerning safety use of the appliance under a person who are responsible for their safety.
- Children should be supervised to ensure that they don't play with the appliance.
- It will cause injury for improper operations.

The meaning of symbol sign









This symbol is used to mark prohibition and please do not do it.



This symbol is used to mark instruction and must follow it.



















CAUTION

 <ul style="list-style-type: none"> • Please disassemble, repair or reconstruct this machine by qualified technical personnel to prevent any unusual work and injury. 	 <ul style="list-style-type: none"> • Please don't pick up the below materials by the machine to avoid fire, explosion or injury. <ul style="list-style-type: none"> ⊙ Explosive powder: Aluminum (Al), Magnesium (Mg), Titanium (Ti) and Zinc (Zn) etc. ⊙ Flammable material: Gasoline, organic solvent, benzene, lamp-oil and paint etc; Chemistry material; Oil and medicine etc. ⊙ Hot material: campfire ashes and cigarette butt etc; the power with spark: High-speed cutting machine, grinding wheel and welding machine etc.
 <ul style="list-style-type: none"> • Do not wipe or pour oil or water into the machine. Moisture entering the product will cause electric shock or wire short. 	 <ul style="list-style-type: none"> • Never operate the product near the explosive, flammable materials such as lamp-oil, gasoline, organic solvent, benzene and paint to avoid fire, explosion or injury.
 <ul style="list-style-type: none"> • Please disconnect the power source before safety checking or cleaning to prevent electric shock or injury. 	 <ul style="list-style-type: none"> • Keep children away from the product to avoid injury.
 <ul style="list-style-type: none"> • Never use damaged power plug, Damaged plug would result electric shock, wire short and fire. 	



NOTICE

 <ul style="list-style-type: none">● Do not use the machine in high temperature environment.	 <ul style="list-style-type: none">● Place the micro-filter in operation to prevent from motor breaking down.
 <ul style="list-style-type: none">● Stop operating when the inlet and exhaust hole are blocked. Otherwise the machine will be deformed by overheat.	 <ul style="list-style-type: none">● Please install wet filter for use with wet pick-up. After wet pick-up, please pouring the residual water and clean the tank. Dry the tank completely.
 <ul style="list-style-type: none">● Please turn off the power and disconnect the piug while installation or maintenance to avoid electric shock and injury.	<p>※ Attention : only for the water sucking vacuum cleaner</p>
 <ul style="list-style-type: none">● Please take off the plug form the socket when the machine doesn't operate to prevent electric leakage, electric shock or fire.	 <ul style="list-style-type: none">● Do not pull the wire to loosen the plug from the outlet. Otherwise, it may cause fire due to short circuit.
 <ul style="list-style-type: none">● Place the filter and paper bag before operation to prevent form the motor breaking down.	 <ul style="list-style-type: none">● Please do not bend, trample on the wire. Also, do not pull it suddenly to cause damage.
 <ul style="list-style-type: none">● Please install the filtration system and filter before using. Otherwise, it will cause the motor breakdown.	 <ul style="list-style-type: none">● Please do not bend or pull the plastic tube. Also, do not trample on and put heavy objects on it to prevent damage and deforation.
 <ul style="list-style-type: none">● Please keep the machine away from fire and heat to reduce the risk of fire and wire short.	 <ul style="list-style-type: none">● Do not touch the plug, power or wire with wet hands to prevent electric shock.
 <ul style="list-style-type: none">● Please do not use the machine in high temperature environment. It will cause damage, electric shock and fire. Please use this machine under 80% humidity.	 <ul style="list-style-type: none">● The life time of the filter depends on its frequency and condition. Change the filter regularly for maintenance.
 <ul style="list-style-type: none">● Please do not keep the sewage and debris in the tank for long time to prevent the odour.	<ul style="list-style-type: none">● Hot air will exhaust from the cooling system which at the top of the machine for normal operation.
 <ul style="list-style-type: none">● Please do not pick up too much dust to cause block of the dust box or motor breakdown.	<ul style="list-style-type: none">● When operate the machine under dry environment (especially in winter), static electricity may be occurred at the frame and part of the machine. Please notice.

Additional safety rules

To use the Vacuum Cleaner safely, besides of the Safety rules of the Operation Instruction, please pay attention to the following:

A

During using the vacuum cleaner, there may be dust inhalation with static electricity, or static electricity is generated due to the friction between the inhaled object and the dust collecting pipe, please stop the operation immediately and remove the static electricity, and remove the dust and waste in the tank and then restart. Please do not close to the precision instruments or machine to avoid damage.



B

Please do not use the same socket with OA machine. The generated attack voltage during switching on/ off will cause OA machines damage.

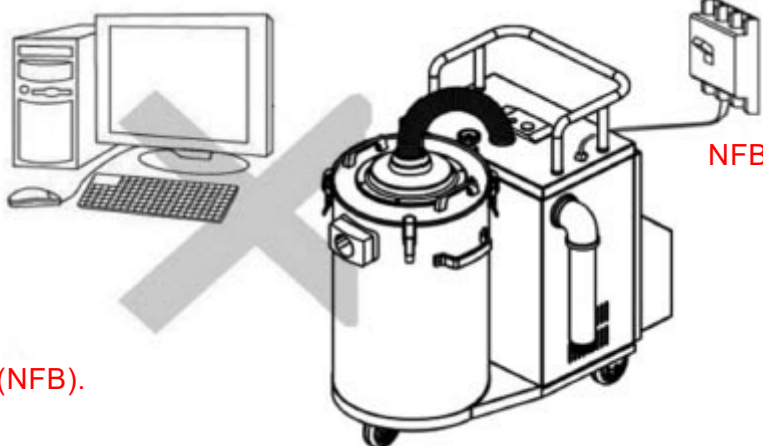

※ This machine must use 20A or more large of No fuse breaker (NFB).

C

Avoid to twist, bend, trample on, pull, forced the hose and unusual storage to make it out of shape and cause damage.

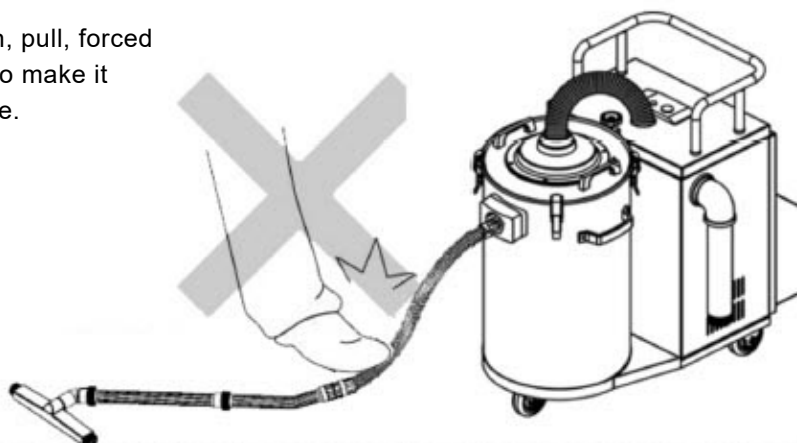

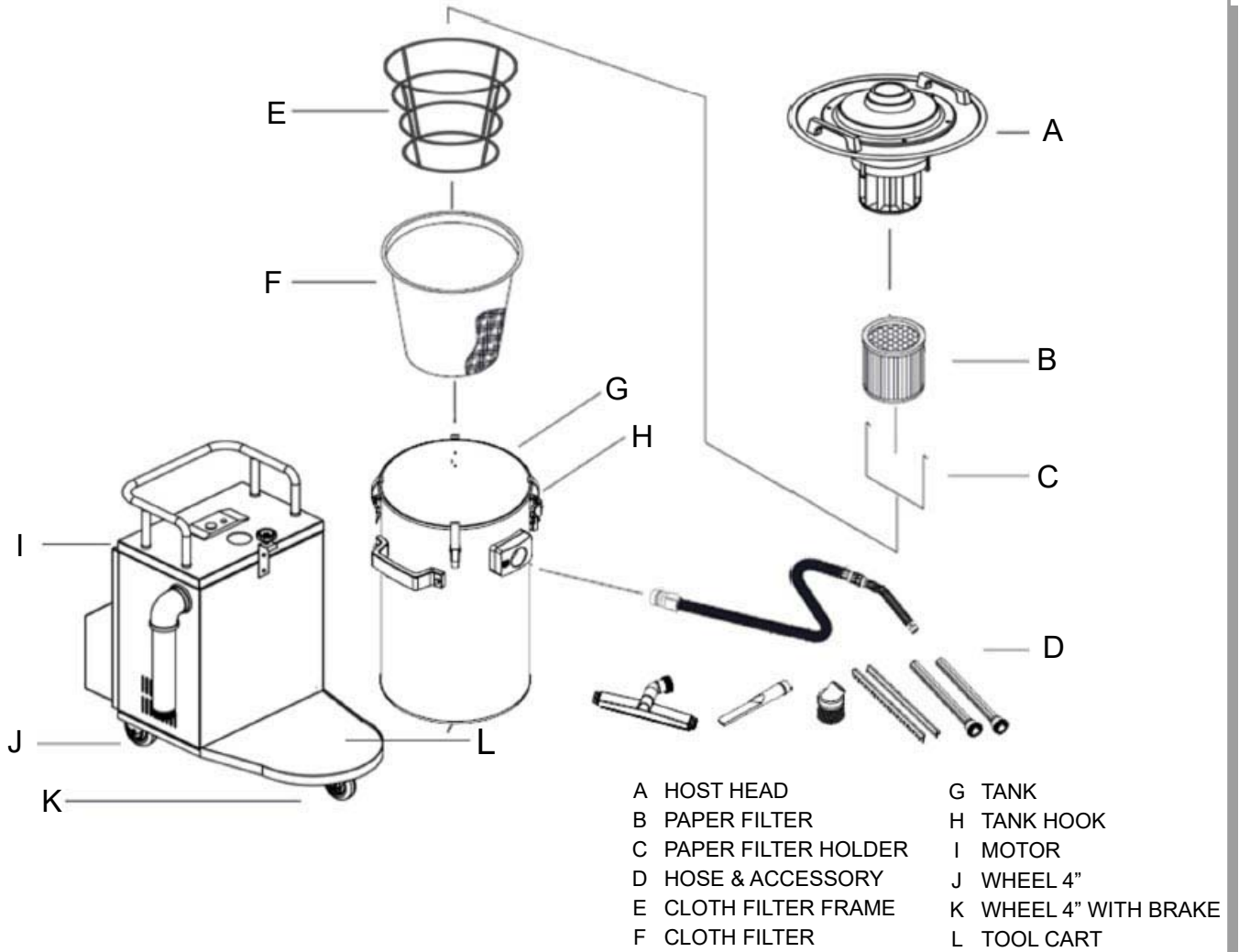

Use Dispose

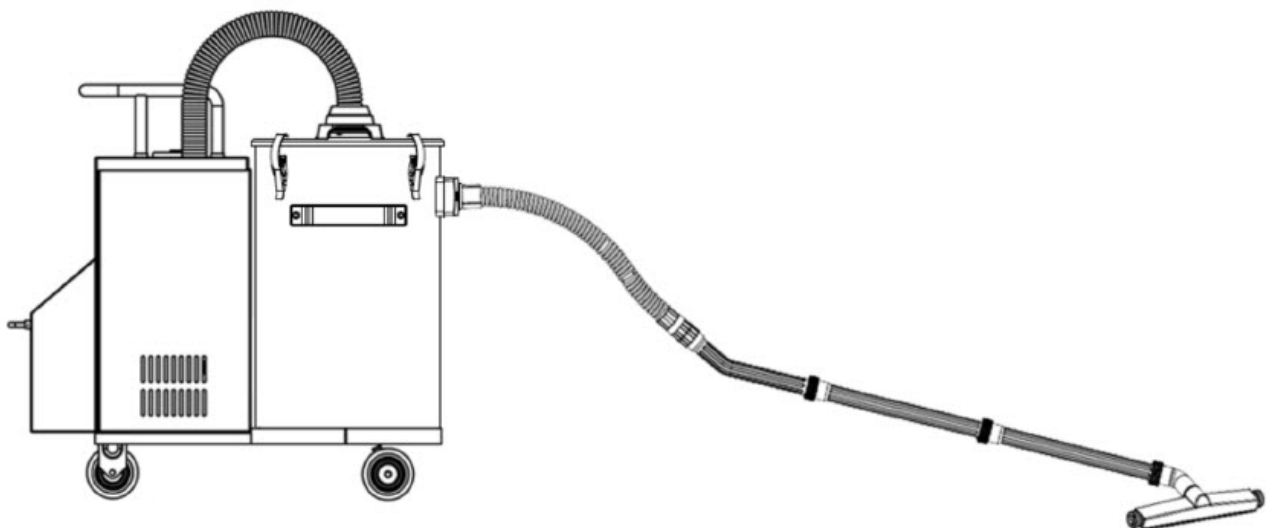

Specifications

Model	JS154		
Voltage	2P/220V/60Hz	3P/220V/60Hz	3P/380V/60Hz
Consumption Power	1750W	1900W	1900W
Drum Capacity	56L	56L	56L
Max Vacuum	1900mmH ₂ O	2100mmH ₂ O	2100mmH ₂ O
Air Flow	4.2m ³ /min±10%	4.2m ³ /min±10%	4.2m ³ /min±10%
Weight	70kg	70kg	70kg
Measurement	970*613*855(mm)	970*613*855(mm)	970*613*855(mm)

Model	JS154		
Voltage	2P/220V/50Hz	3P/220V/50Hz	3P/380V/50Hz
Consumption Power	1500W	1750W	1750W
Drum Capacity	56L	56L	56L
Max Vacuum	1900mmH ₂ O	2200mmH ₂ O	2200mmH ₂ O
Air Flow	3.6m ³ /min±10%	3.6m ³ /min±10%	3.6m ³ /min±10%
Weight	70kg	70kg	70kg
Measurement	970*613*855(mm)	970*613*855(mm)	970*613*855(mm)

Parts Name

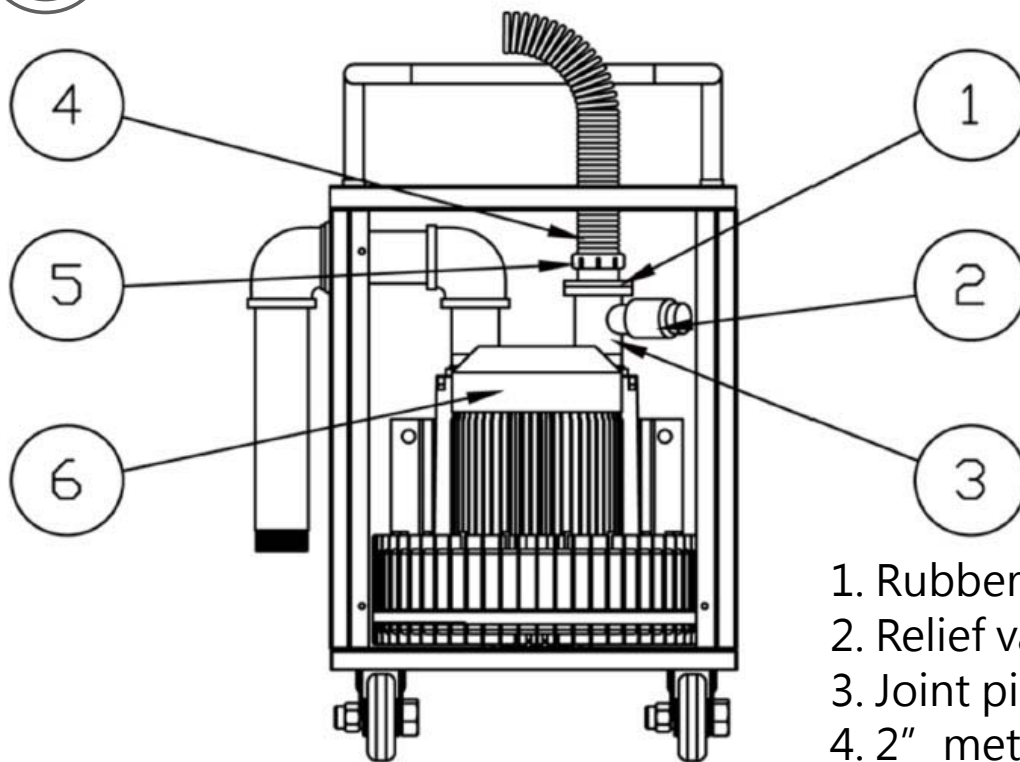

1. Rubber pad
2. Relief valve
3. Joint pipe
4. 2" metal hose
5. 2" Fixed ring of metal hose
6. Blower

Operation usage

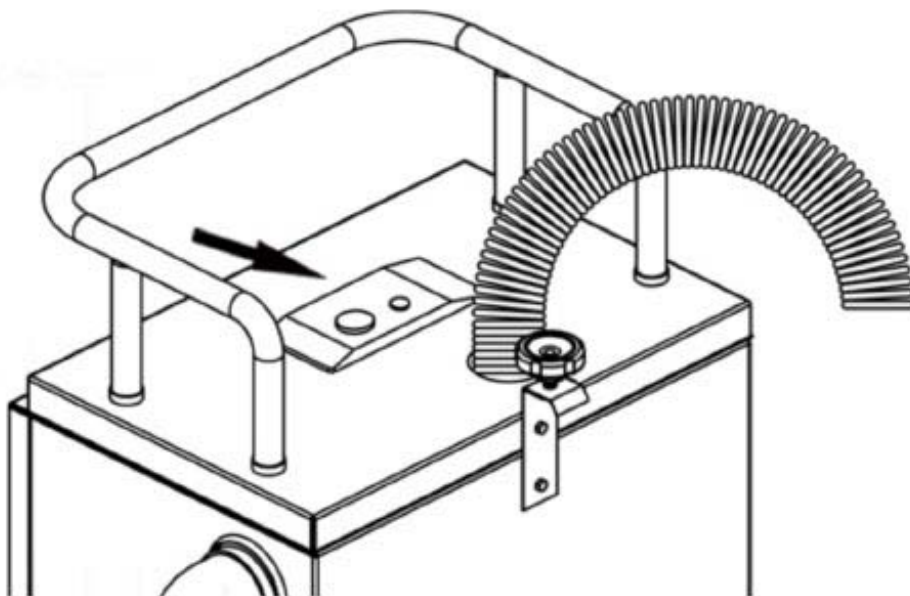

1. Press the green of button to start the machine.
2. Press the red of button to stop the machine.

Standrad accessory

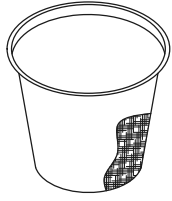

Cloth Filter

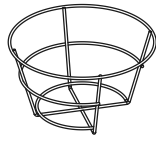

Cloth Filter

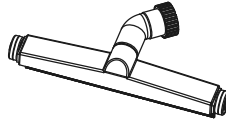

Master nozzle

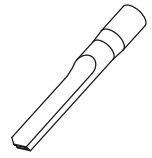

Crevice nozzle-A

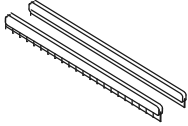

Inhale water piece

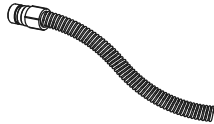

Hose-A

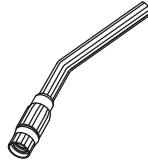

Curved pip

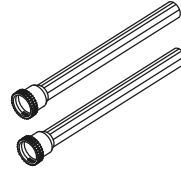

Extension pipes



Round nozzle

Simple accessory

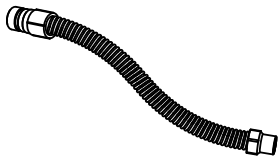

Hose-B

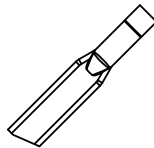

Crevice nozzle-B

Optional accessory

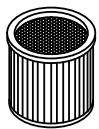

HEPA Filter

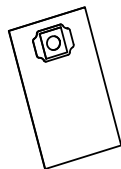

Cloth Filter



Additional Paper filter

※When sucking liquid materials,
please take out the paper filter.

Accessory Usage

1 Plastic master nozzle

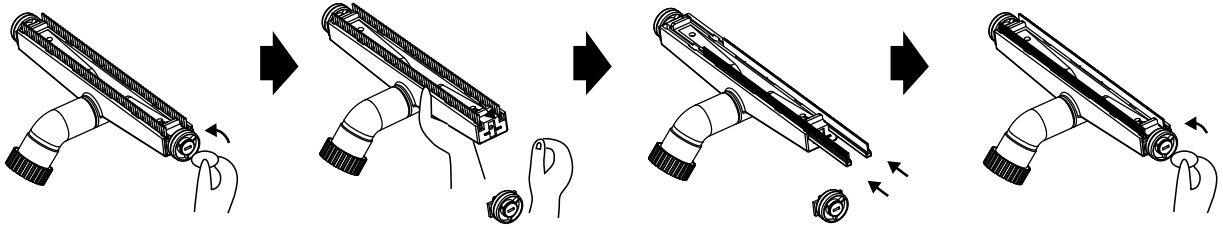

1. Turn the master nozzle to the back side and using one coin or screw driver to take out wheel out from the side with arrow tip.

2. Take out the brush chips.

3. Insert the squeegee shoe in.

4. Assemble the master nozzle & wheel.

2 Extension pipes usage

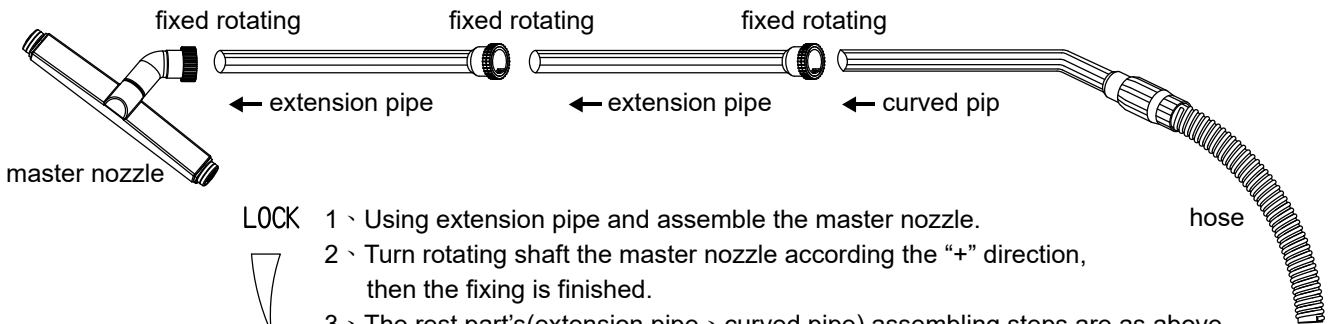

LOCK



OPEN

1 \ Using extension pipe and assemble the master nozzle.

2 \ Turn rotating shaft the master nozzle according the "+" direction, then the fixing is finished.

3 \ The rest part's(extension pipe \ curved pipe) assembling steps are as above,

4 \ If you want to disassemble each parts, please turn the rotating shaft according to "-" or "OPEN" direction.

3 Place for using different spare parts

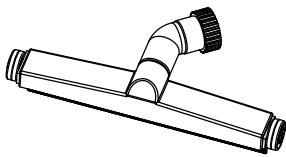

Wet nozzle

Recommend using for cleaning water

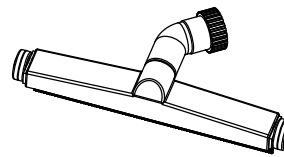

Master nozzle

Recommend using for floor or carpet.

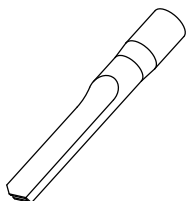

Crevice nozzle

Recommend using for small area.



Round nozzle

Recommend using for irregular shape or soft material goods.

Removing sewage and debris



⚠ Notice

Please turn off and disconnect the plug and release the side clips.

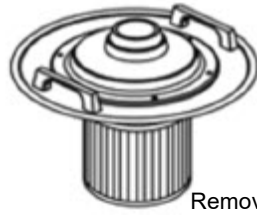

Remove the head unit and store in a proper place to prevent contamination and damage.

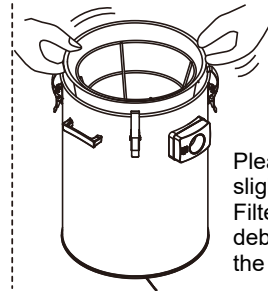

Please make sure to slightly shake the Cloth Filter for removing the debris before take out the filter from the tank.



Please turn on the nut.



Please empty the collected dust and debris separately accordance with legal regulations.

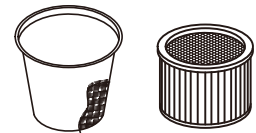

- Cloth filter- water washable.
 - Paper filter- available to use soft brush for periodically cleaning.
- ※ In a regularly maintenance, we would suggest you to replace cloth filter, paper filter periodically per 3 months. Please also replace it according to exact using situation.

General Error Solution and Maintenance

PROBLEM	CHECK	SUGGESION
Motor does not operate	Power	Please use multimeter to check the power.
Cleaner fails to pick up	Hose	Maybe the hose or extension wands didn't fit completely. please refit it.
	Inside of tank	Please check if the tank is full and empty it.
	Filter	Please check the filter and filtration system and clean it.



- Check: Please check the parts or accessories (Hose, wire, paper bag, filter rack and filter) if need to be replaced.
- If the power cord is damage, please requests profession and technical personnel to replace it.

- Maintenance and Lubrication:
 1. Do not lubricate the motor.
 2. Clean the machine outside regularly.

Standrad accessory

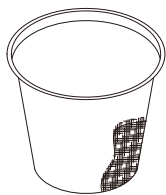

● Cloth filter

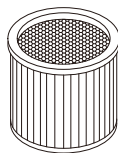

● Paper filter

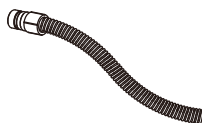

● Hose

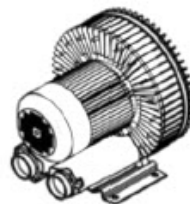

● Blower



● Wheel 4" with brake



● Wheel 4"

Product Warranty:

1. This product comes with a one- year full warranty from the date of purchase with the normal using.
2. The range of warranty is covered the unit and parts, but consumable items are not covered by this warranty.
3. It has to be charged during the guarantee period under the situations as below:
 - a. Incorrect using or any unit that has been modified in any way causes the failure or damages.
 - b. Failure caused by accident drop or falling clean in moving.
 - c. During the guarantee period, if repair can't be done because of the parts are stop for production or modified for better replacement; we may charge the price difference of better replacement.
 - d. The natural disaster, social effects of pollution and incorrect voltage cause the failure or damages.
4. If lose this warranty, don't reissue again.
5. We reserve right to change products and specification at any time without prior notice.

Warranty

Product name: JS154

Data of the Supplier: ____ (yyyy) ____ (mm) ____ (dd)

(This product comes with a one- year full warranty from the date of purchase with the normal using.)

Name:

Address :

Stamp of the store :